



# EXPERT 400

## STONE SAWS

*Designed and made in Italy*

### CONTROL BOARD

- Switch with release coil
- Overheat protection in the event of the disk jamming
- Laser instrument for the maximum cutting precision (optional in standard version).

### KIT WHEELS

The wheels are Ø220 mm and can be fixed at the legs by means eyebolts. Due to their conception and for the legs' inclination, are very functional and allow the machine to be easily moved if lightly lifted up by the handles.

### STORAGE

Build to reduce at the maximum the encumbrance during the carriage and above all the storage space.

	Art. 9401	Art. 9400
DIAMOND DISK (not included)	Ø400 mm. (int Ø25,4 mm.)	Ø400 mm. (int Ø25,4 mm.)
ENGINE	230V   50Hz 3,8Hp/2,8kW	230V   50Hz 3,8Hp/2,8kW
ROTATION SPEED	2800 rpm.	2800 rpm.
AMPEROMETRICAL PROTECTION	16A	16A
MAX CUTTING LENGTH	800 mm.	800 mm.
MAX CUTTING WIDTH	550 mm.	550 mm.
MAX CUTTING DEPT H	135 mm.	135 mm.
MAX CUTTING DEPTH WITH 2 RUNS	155 mm.	155 mm.
WORKING TABLE SIZE	515 x 442 mm.	515 x 442 mm.
WATER RECYCLING PUMP TYPE	S2 230V – 50Hz / 60W	S2 230V – 50Hz / 60W
KIT WHEELS	Standard	Optional
LASER INSTRUMENT	Standard	Optional
DIMENSION MACHINE IN SERVICE	760x1180x h. 1325 mm.	760x1180x h. 1325 mm.
DIMENSION MACHINE IN STOCK	800x1200x h. 970 mm.	800x1200x h. 970 mm.
DIMENSION 3 MACHINES ON PALLET	800x1200x h. 2270 mm.	800x1200x h. 2270 mm.
NET WEIGHT	73 Kg.	68 Kg.



**BATTIPAV**<sup>TM</sup>  
MACCHINE PER EDILIZIA | MACHINES FOR BUILDING

Z. i. 2 - Via Cavatorta, 6/1 | 48010 Cotignola (Ra) | ITALY  
Tel. +39 0545 40004 | Fax +39 0545 41724  
[www.battipav.com](http://www.battipav.com) | [sales@battipav.com](mailto:sales@battipav.com)

AUTHORIZED DEALER:



February 2013



### APPLICATION

Built to cut bricks, kerbs, tuff and all the different kind of material for the building sector.



- Strong framework holding the motor group
- Strong motor 3,8 Hp / 2,8 kW for disk Ø400
- Indicator for the cut in 2 runs.

**Spray system**  
DISK'S LUBRICATION



The cutting head is tilting and can be locked at the intended height.



The cutting position with sliding carriage.



**LASER TRACER**

- Connected directly to the net.
- Bulb with millimetrical adjustment of the ray in three space's directions.
- Lens with interchangeable protection glass.

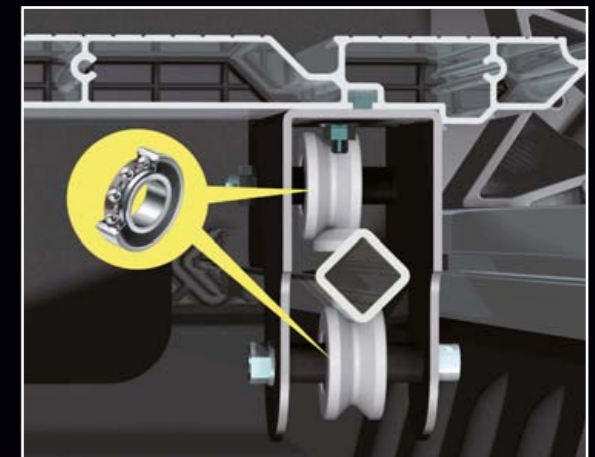

**wdec**  
WATER DECANTING SYSTEM

The working table is very strong and steady.

- It slides on 2 steel square rails with 6 wheels; 4 over and 2 under.
- Every wheel has 2 ball bearings for a total of 12.

**FastLEG**  
LEG FASTENING SYSTEM



ORIGINAL RECYCLING PUMP