

# LAMPO *cut* EASY *break*

IT

ISTRUZIONI PER L'USO DEL  
LAMPOCUT & EASYBREAK

GB

INSTRUCTIONS FOR USE OF THE  
LAMPOCUT & EASYBREAK

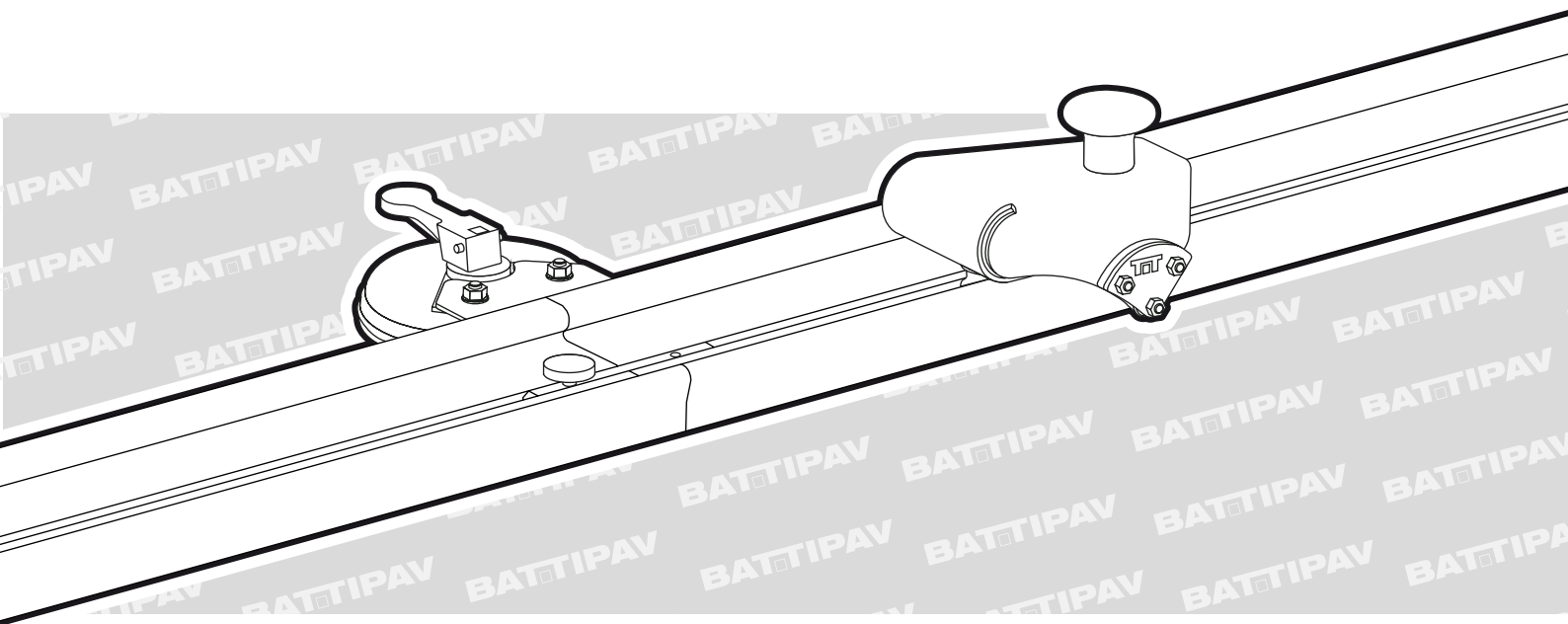

Manual Video

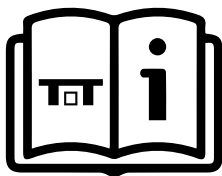

**BATTIPAV**<sup>TM</sup>

MACCHINE PER EDILIZIA | MACHINES FOR BUILDING

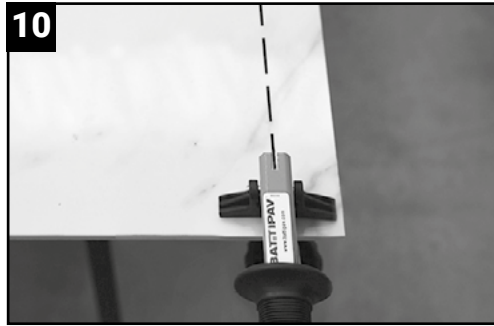
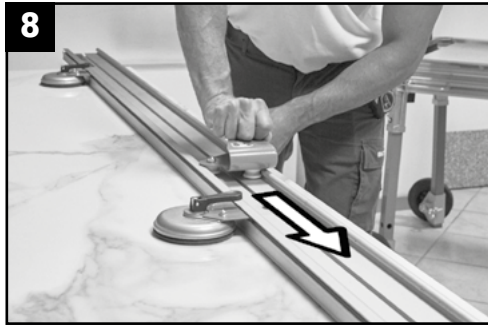
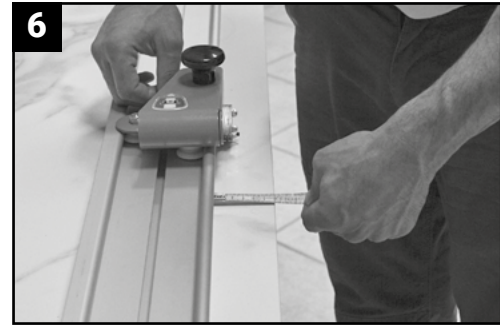
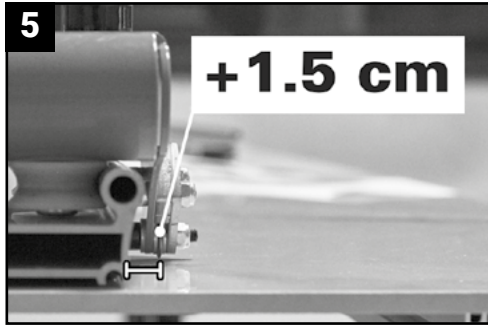
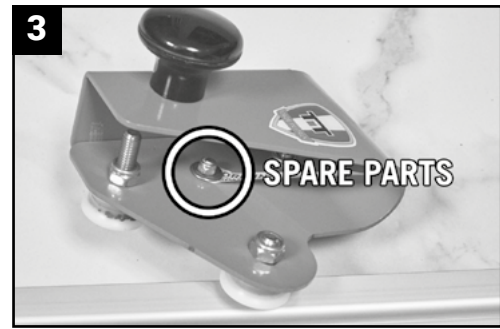
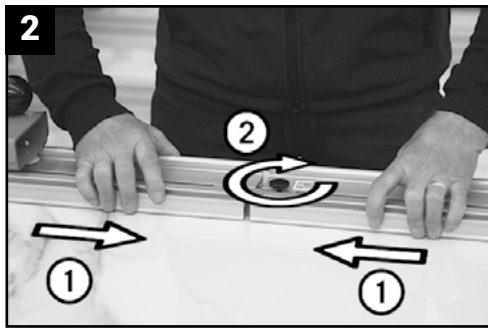

**LAMPO cut**  
**EASY break**

**BATTIPAV™**  
MACCHINE PER EDILIZIA | MACHINES FOR BUILDING

